

HYUNDAI
POWER PRODUCTS

**BOOSTER PUMP
HBP1300-A**

ORIGINAL INSTRUCTIONS



GENUINE PRODUCT OF
HYUNDAI CORPORATION

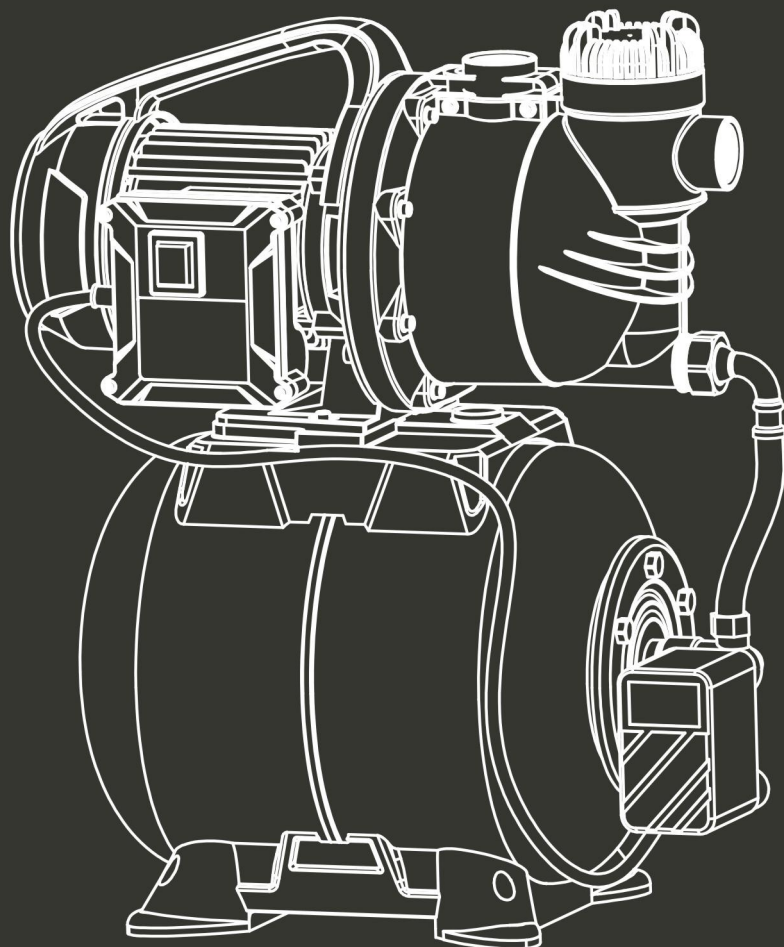

WARNING: Read thoroughly the instruction manual before using.

SAFETY WARNINGS

Please note that all instructions must be consulted! Failure to observe the following instructions and warnings may result in electric shock, fire and / or serious injury. Keep all instructions and warnings for future reference. If you are giving this device to another person, please provide this instruction manual as well.

- This appliance can be used by children aged from 8 years and above and persons with reduced physical, sensory or mental capabilities or lack of experience and knowledge if they have been given supervision or instruction concerning use of the appliance in a safe way and understand the hazards involved. Children shall not play with the appliance. Cleaning and user maintenance shall not be made by children without supervision.
- If the supply cord is damaged, it must be replaced by the manufacturer, its service agent or similarly qualified persons in order to avoid a hazard.
- Use this unit as described in this manual. Any mishandling or use contrary to these instructions will in no case be the responsibility of the manufacturer.
- Failure to observe the safety and operating instructions may cause a risk of electric shock, fire and / or injury to persons.

- Do not use attachments other than those recommended by the manufacturer; they can damage the unit and / or cause injury.
- DANGER OF SUFFOCATION! Keep packaging materials out of the reach of children.
- Before any connection, check:
 - Do not damage the device or cable. In this case, do not use the appliance and take it to your dealer for inspection and repair.
 - That the voltage indicated on the rating plate of the appliance corresponds to that of your electrical installation.
- Do not disassemble the device yourself. Any disassembly, repair or inspection should be carried out exclusively by a qualified service.
- The supply cord must be easily accessible.
- The pump must be supplied through a residual current device (RCD) having a rated residual operating current not exceeding 30 mA.
- Protect the appliance and electrical connections against moisture.
- In case of flood danger, protect the connectors.
- Avoid the discharge of aggressive liquids and the discharge of abrasive materials.

- The submersible motor pump must be protected from freezing.
- The submersible motor pump must not run dry.
- Disconnect the pump from the supply mains before carrying out user maintenance such as cleaning the filter.

SYMBOLS



Read the instruction manual

INTENDED USE

The pump has been designed to suck clear water and water with particles. The pump must be installed on a flat and solid surface. It is not suitable for professional use (including continuous operation).

DESCRIPTION

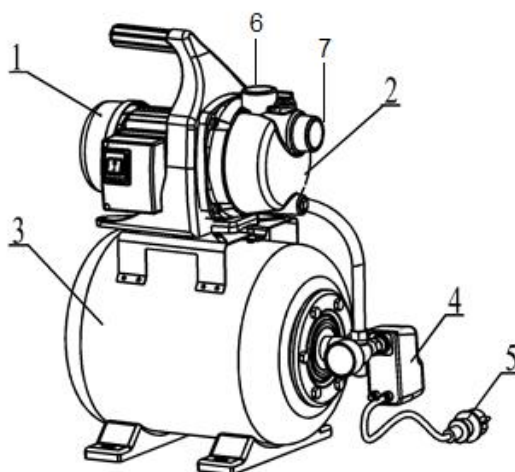

- 1 Motor cover
- 2 Pump head
- 3 Pressure cylinder
- 4 Pressure switch
- 5 Cable
- 6 Discharge pipe connection
- 7 Suction hose connection

Technical Parameters

Model	HBP1300-A
Input voltage	230V~ 50Hz
Input power	1300W
Max. total head	50m
Max. flow rate	4500l/h
Max. suction height	8m
Temperature max	35°C

Functions

Caution: This water pump has a water-sprinkling protection feature and should be placed only in a dry environment. Never place the water pump or operate it in the rain or in a humid space.

Caution: This water pump should not be used with flammable or harmful liquids.

Caution: Idle operation of the water pump must be avoided.

Caution: This water pump is for work in clean water. The scope of its application includes irrigation in the garden, water supply to a household, sprinkling in a garden or on farmland.

- This water pump may not be exposed for long periods to impurities, sand, stone, sticky substances, etc., mixed in with the conveyed media. Because the conveyed media may contain chemical corrosive substances, it is necessary to pay special attention to preventing influence by these on the material of the pump body. It is not permitted to use this water pump to convey drinking water.

Power connection

General description

Danger: During the installation of the water pump, the power supply to the water pump must be switched off.

Caution: During installation of the equipment, it is necessary to keep it under dry and well-ventilated conditions, at an ambient temperature below 40°C.

- Before use, the water pump should be inspected for safety to ensure that there is no damage to the power cable or the plug.

Electrical connection:

Danger: The Electrician responsible for installation must check to ensure that the electrical connection is in accordance with the standard, including the earth terminal.

- The water pump must be well earthed. If it is necessary to increase the length of the original cable, a cable with the same section as the original cable must be used.

Taking into use

Before carrying out any work on your pump, make sure that it is switched off and that the power supply is cut off.

The pump is not a self-priming pump. To function, it must be full of water. This is why it is necessary to prime the water pump before operating it, during installation or after each storage period.

The suction hose must first of all be equipped with:

- A non-return valve with filter; this ensures that after disconnecting the pump, the hose and the pump will not run dry. This part of the hose must be put in the water for it to be pumped.
- A pipe with a coupling nut; this end of the hose is attached to the front of the pump.

The two accessories must be securely screwed onto the pipe using the hose clamp supplied.

Immerse the suction hose in the source of water to be pumped to fill it with water.

Make sure that the water level does not drop when you remove it from the water.

Disconnect the discharge hose.

Unscrew the priming plug on the pump and fill it with water (use a bottle or similar container) until it overflows.

Screw the cap back on.

Connect the discharge pipe, connect the pump to the electricity supply and start it up.

Pressure hose

- The pressure hose is used for conveying the water from the pump to the water consumption point (e.g. tap, etc.) in order to minimize the friction loss caused by the water pressure, we recommend that you use a pressure hose with diameter of 1".

Discharge pipe diameter	33.3mm
Suction pipe diameter	33.3mm

Maintenance

- The appliance only needs an external regular cleaning.
- Before cleaning the appliance, always unplug plug from supply and wait till the unit stop.
- Do not clean the painted parts with emery or solvents and use only a moistened cloth.
- If trouble with the pump is experienced, it must be repaired by professional personnel or service centre

Cleaning and Care

Proper and regular care will not only ensure safe use but also elongate the lifetime of this appliance.

Warning! Switch of the appliance and disconnect from power supply before you carry out cleaning and maintenance work to avoid electrical hazard.

a) Wipe dust off with a soft dry cloth or brush.

b) To clean other debris you may use a slightly wet cloth and neutral detergent.

Note! Do not use chemical, alkaline, abrasive or other aggressive detergents or disinfectant to clean this appliance as these might be harmful to its surface.

Repair and Maintenance

This appliance does not contain any user serviceable parts. Do not try to repair the appliance yourself. Always bring it to qualified technician.

Disposal



This marking indicates that this product should not be disposed with other household wastes throughout the EU. To prevent possible harm to the environment or human health from uncontrolled waste disposal, recycle it responsibly to promote the sustainable reuse of material resources. To return your used device, please use the return and collection systems or contact the retailer where the product was purchased. They can take this product for environmental safe recycling.

Warranty

The manufacturer guarantees the product against defects in material and workmanship for a period of 2 years from the date of the original purchase. It can be extended by one year if the user subscribes to website of myswap. The warranty only applies if the product is for household use. The warranty does not cover breakdowns due to normal wear and tear.

The manufacturer agrees to replace parts identified as defective by the designated distributor. The manufacturer does not accept responsibility for the replacement of the machine, in whole or in part, and/or ensuing damage.

The warranty does not cover breakdowns due to:

- insufficient maintenance.
- abnormal assembly, adjustment or operations of the product.
- parts subject to normal wear and tear.

The warranty does not extend to:

- shipping and packaging costs.
- using the tool for a purpose other than that for which it was designed.
- the use and maintenance of the machine done in a manner not described in the user manual.

Due to our policy of continuous product improvement, we reserve the right to alter or change specifications without notice. Consequently, the product may be different from the information contained therein, but a modification will be undertaken without notice if it is recognized as an improvement of the preceding characteristic.

READ THE MANUAL CAREFULLY BEFORE USING THE MACHINE.

When ordering spare parts, please indicate the part number or code, you can find this in the spare parts list in this manual. Keep the purchase receipt; without it, the warranty is invalid. To help you with your product, we invite you to contact us by phone or via our website:

+33 (0)9.70.75.30.30

<https://services.swap-europe.com/contact>

You must create a "ticket" via the web platform.

- Register or create your account.
- Indicate the reference of the tool.
- Choose the subject of your request.
- Describe your problem.

Attach these files: invoice or sales receipt, photo of the identification plate (serial number), photo of the part you need (for example: pins on the transformer plug which are broken).



swap

WHAT TO DO IF MY MACHINE BREAKS DOWN?

If you bought your product in a store:

- Make sure that your machine is complete with all accessories supplied, and clean! If this is not the case, the repairer will refuse the machine.
- Go to the store with the complete machine and with the receipt or invoice.

If you bought your product on a website:

- Make sure that your machine is complete with all accessories supplied, and clean! If this is not the case, the repairer will refuse the machine.
- Create a SWAP-Europe service ticket on the site: <https://services.swap-europe.com> When making the request on SWAP-Europe, you must attach the invoice and the photo of the nameplate (serial number).

Contact the repair station to make sure it is available before dropping off the machine.

Go to the repair station with the complete machine packed, accompanied by the purchase invoice and the station support sheet downloadable after the service request is completed on the SWAP-Europe site

Please keep your original packaging to allow for after-sales service returns or pack your machine with a similar cardboard box of the same dimensions.

For any question concerning our after-sales service you can make a request on our website <https://services.swap-europe.com>

Our hotline remains available at +33 (9) 70 75 30 30.



THE WARRANTY DOES NOT COVER:

- Start-up and setting up of the product.
- Damage resulting from normal wear and tear of the product.
- Damage resulting from improper use of the product.
- Damage resulting from assembly or start-up not in accordance with the user manual.
- Periodic and standard maintenance events.
- Actions of modification and dismantling that directly void the warranty.
- Products whose original authentication marking (brand, serial number) has been degraded, altered or withdrawn.
- Replacement of consumables.
- The use of non-original parts.
- Breakage of parts following impacts or projections.
- Accessories breakdowns.
- Defects and their consequences linked to any external cause.
- Loss of components and loss due to insufficient screwing.
- Cutting components and any damage related to the loosening of parts.
- Overload or overheating.
- Poor power supply quality: faulty voltage, voltage error, etc.
- Damages resulting from the deprivation of enjoyment of the product during the time necessary for repairs and more generally the costs related to the immobilization of the product.
- The costs of a second opinion established by a third party following an estimate by a SWAP-Europe repair station
- The use of a product which would show a defect or a breakage which was not the subject of an immediate report and/or repair with the services of SWAP-Europe.
- Deterioration linked to transport and storage*.

* In accordance with transport legislation, damage related to transport must be declared to carriers within 48 hours maximum after observation by registered letter with acknowledgement of receipt. This document is a supplement to your notice, a non-exhaustive list.

Attention: all orders must be checked in the presence of the delivery person. In case of refusal by the delivery person, it you must simply refuse the delivery and notify your refusal.

Reminder: the reserves do not exclude the notification by registered letter with acknowledgement within 72 hours.

Information:

Thermal devices must be wintered each season (service available on the SWAP-Europe site). Batteries must be charged before being stored.

HYUNDAI
POWER PRODUCTS



For inquiries, please contact:

BUILDER SAS

32 rue Aristide Bergès - Z.I. du Casque - 31270 Cugnaux - France

Tél.: +33(0)5.34.502.502 Fax.: +33(0)5.34.502.503

<http://www.hyundaipower-fr.com/>

Fabriqué en République Populaire de Chine(PRC)